

AUTOMAZIONE PER VALVOLE  
VALVE AUTOMATION

AUTOMATION POUR LES VANNES  
AUTOMATISIERUNG FÜR KUGELHÄHNE

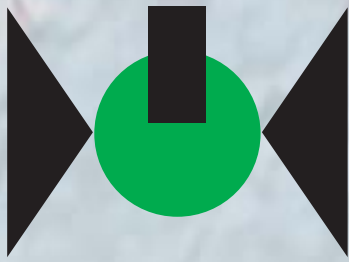

**ALFA**®  
**VALVOLE** s.r.l.

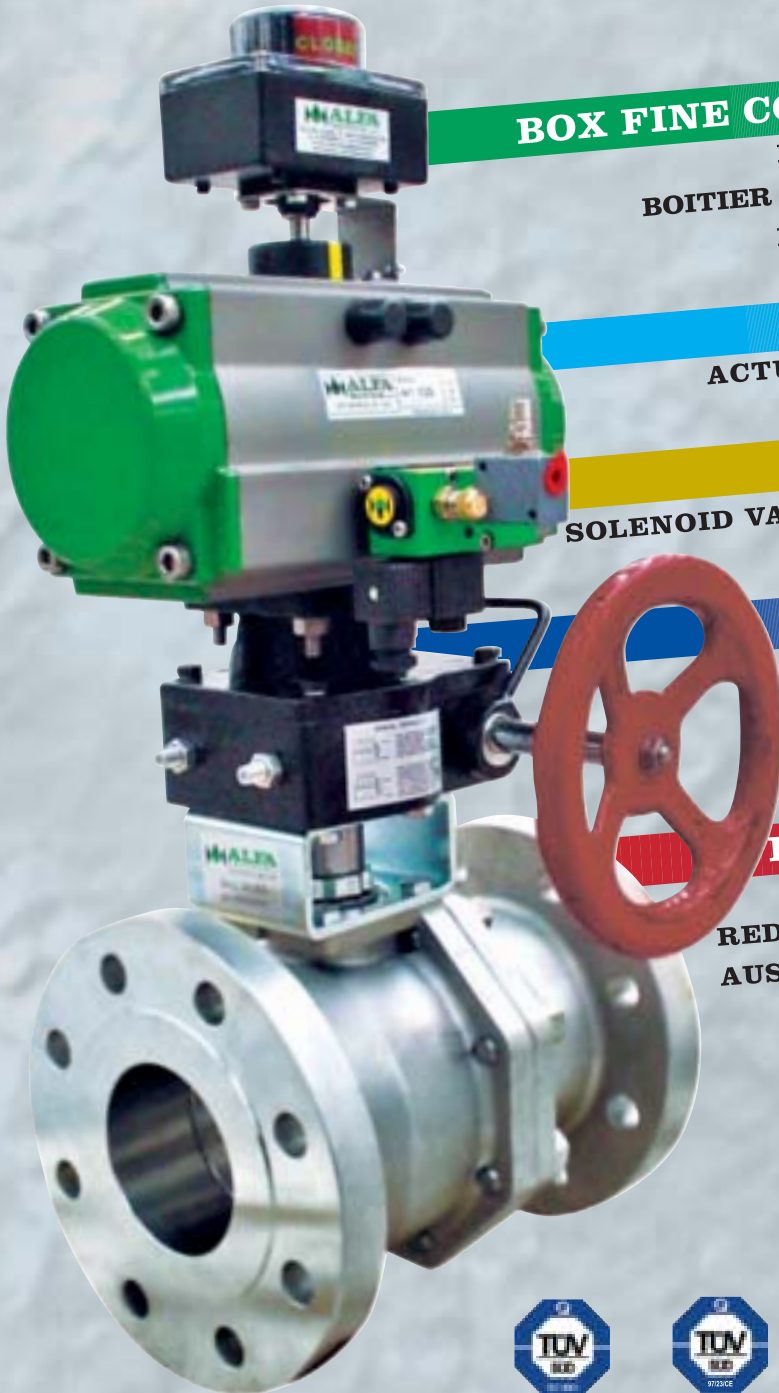

**BOX FINE CORSA/POSIZIONATORE**  
LIMIT SWITCH BOX/POSITIONER  
BOITIER FIN DE COURSE/ POSITIONNEUR  
ENDSCHALTERBOX/ POSITIONER

**ATTUATORE**  
ACTUATOR ACTIONNEUR ANTRIEB

**ELETTROVALVOLA**  
SOLENOID VALVE ELECTRODISTRIBUTEUR  
MAGNETVENTIL

**ACCESSORI**  
ACCESSORIES  
ACCESSOIRES  
ZUBEHÖR

**RIDUTTORE A SGANCIO**  
DECLUTCHABLE GEAR BOX  
REDUCTEUR MANUEL DEBRAYABLE  
AUSKUPPELBARES HANDGETRIEBE



UNI EN ISO 9001:2000  
Nr. 50 100 6417



CE 0948-Modulo H  
Certificato nr. PED-0948-QSH-274-07



CEC-06 / 2037-ADF178  
Directive 94/9/EC - Article 8 (1) b) ii)



Cert. n. 6D-0195

Proprietà riservata - A termine delle vigenti leggi questo documento non potrà essere copiato, riprodotto o comunicato ad altre persone o a ditte senza la nostra autorizzazione scritta.  
All rights reserved - No part of this reproduced or transmitted, in any form or by any means, electronic, mechanical, photocopying, recording or otherwise, without the prior permission of ALFA VALVOLE s.r.l.

Ed.0004/04.09

Le caratteristiche delle valvole, con esclusione di quelle regolamentate da Norme internazionali, possono essere oggetto di modifiche senza preavviso.  
Design and specifications are subject to change without notice, except those established by international standards.



20010 CASOREZZO (Milano) - ITALIA -  
VIALE DEL LAVORO, 19  
Tel. 02.90296206 r.a. - Telefax 02.90296292 -  
E-Mail: [alfavalvole@alfavalvole.it](mailto:alfavalvole@alfavalvole.it) - Sito internet: [www.alfavalvole.it](http://www.alfavalvole.it)

**ATTUATORI PNEUMATICI  
PNEUMATIC ACTUATORS  
ACTIONNEURS PNEUMATIQUES  
PNEUMATISCHE STELLANTRIEBE**

**PER VALVOLE "ALFA" A VIA DIRITTA  
FOR STRAIGHT WAY "ALFA" VALVES  
POUR VANNES "ALFA" À VOIE UNIQUE  
FÜR "ALFA" DURCHGANGSKUGELHÄHNE**

# AVT 90°

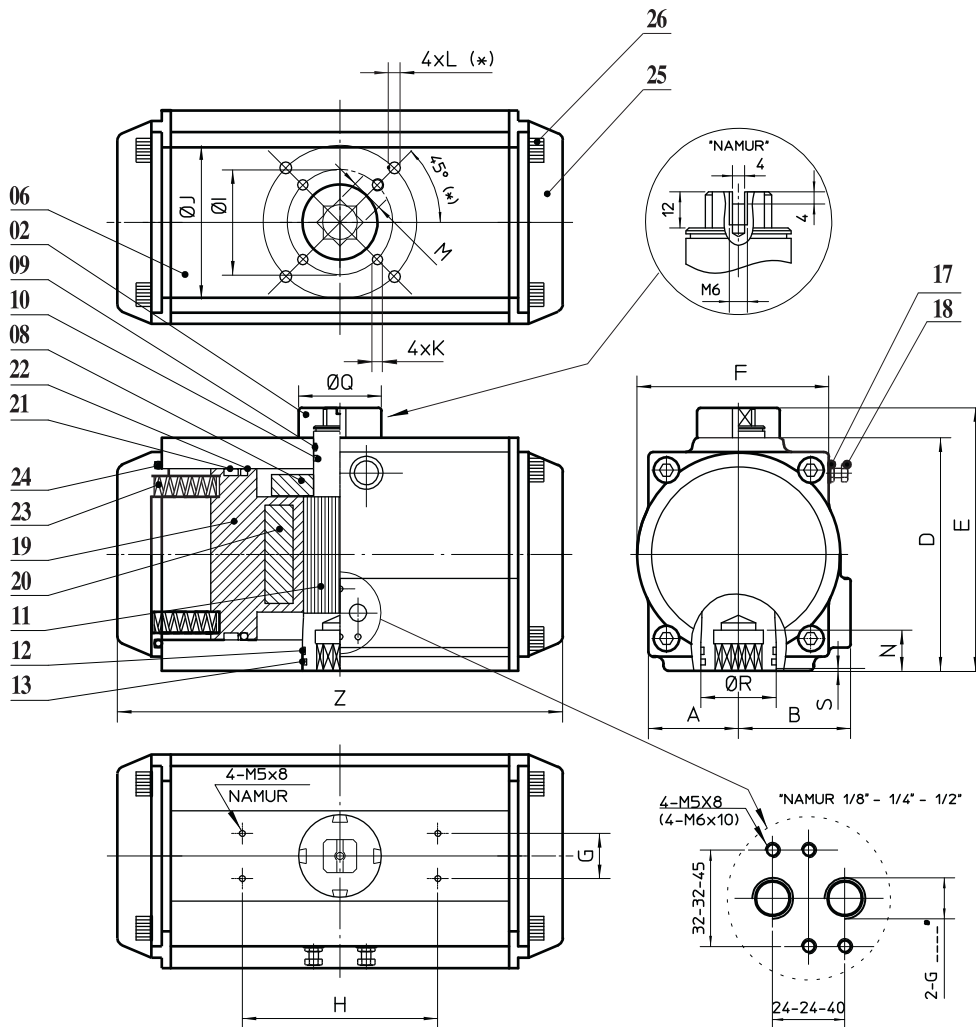

NOTA (\*): AVT 400 - F25 8xL 22°30"  
NOTE (\*): AVT 400 - F25 8xL 22°30"  
NOTE (\*): AVT 400 - F25 8xL 22°30"  
ANMERKUNG (\*): AVT 400 - F25 8xL 22°30"

Model	A	B	D	E	F	G	H	ØI (ISO)	ØJ (ISO)	K	L	M	N	ØQ	ØR	S	Z	Air connection	Kg
045	29	29	65	95	58	30	80	36 (F03)	50 (F05)	M5x8	M6x10	11	14	40	23	1.5	146	NAMUR G1/8"	1.1
052	30	41	72	92	65	30	80	36 (F03)	50 (F05)	M5x8	M6x10	11	14	40	23	1.5	147	NAMUR G1/4"	1.5
063	36	47	87	107	72	30	80	50 (F05)	70 (F07)	M6x10	M8x13	14	18	40	28	1.5	168	NAMUR G1/4"	2.2
075	42	53	99	119	81	30	80	50 (F05)	70 (F07)	M6x10	M8x13	14	18	40	28	1.5	184	NAMUR G1/4"	2.9
083	46	57	109	129	92	30	80	50 (F05)	70 (F07)	M6x10	M8x13	17	21	40	35	1.5	204	NAMUR G1/4"	3.6
092	50	58	117	137	98	30	80	50 (F05)	70 (F07)	M6x10	M8x13	17	21	40	39	1.5	262	NAMUR G1/4"	5.5
105	57	64	133	153	109	30	80	70 (F07)	102 (F10)	M8x13	M10x16	22	26	40	46	1.5	268	NAMUR G1/4"	6.7
125	67	74	155	175	127	30	130	70 (F07)	102 (F10)	M8x13	M10x16	22	26	55	50	1.5	296	NAMUR G1/4"	11
140	75	77	171	191	137	30	130	102 (F10)	125 (F12)	M10x16	M12x20	27	31	55	67	1.5	390	NAMUR G1/4"	15
160	87	87	197	217	158	30	130	102 (F10)	125 (F12)	M10x16	M12x20	27	31	55	78	2	454	NAMUR G1/4"	23
190	103	103	230	260	189	30	130		140 (F14)		M16x25	36	40	80	90	2	525	NAMUR G1/4"	46
210	113	113	255	285	210	30	130		140 (F14)		M16x25	36	40	80	90	2	532	NAMUR G1/4"	53
240	130	130	288	318	245	30	130		165 (F16)		M20x25	46	50	80	102	3	610	NAMUR G1/4"	73
270	147	147	326	356	273	30	130		165 (F16)		M20x25	46	50	80	102	3	722	NAMUR G1/2" (1/4")	116
300	162	162	348	378	324	30	130		165 (F16)		M20x25	46	60	80	102	3	742	NAMUR G1/2"	130
350	190	190	402	432	380	30	130		165 (F16)		M20x25	46	60	80	102	3	860	NAMUR G1/2"	235
400	258	258	464	494	516	30	130	165 (F16)	254 (F25)	M20x25	M16x25	55	60	80	117	3	924	NAMUR G1/2"	360

Proprietà riservata - A termine delle vigenti leggi, questo documento non potrà essere copiato, riprodotto o comunicato ad altre persone o a ditte senza la nostra autorizzazione scritta. All rights reserved - No part of this reproduced or transmitted, in any form or by any means, electronic, mechanical, photocopying, recording or otherwise, without the prior permission of ALFA VALVOLE s.r.l.

Ed.0004/04\_09/00001

Le caratteristiche delle valvole, con esclusioni di quelle regolamentate da Norme internazionali, possono essere oggetto di modifiche senza preavviso. Design and specifications are subject to change without notice, except those established by international standards.



20010 CASOREZZO (Milano) - ITALIA -  
VIALE DEL LAVORO, 19  
Tel. 02.90296206 r.a. - Telefax 02.90296292 -  
E-Mail: [alfavalvole@alfavalvole.it](mailto:alfavalvole@alfavalvole.it) - Sito internet: [www.alfavalvole.it](http://www.alfavalvole.it)

# AVT 90°

## MATERIALI - MATERIALS - MATERIAUX - WERKSTOFFE

02	INDICATORE DI POSIZIONE	POSITION INDICATOR	INDICATEUR DE POSITION	STELLUNGSANZEIGE	PLASTICA PLASTIC PLASTIQUE KUNSTSTOFF
06	CORPO	BODY	CORPS	GEHAUSE	ALLUMINIO ALUMINIUM ALUMINIUM ALUMINIUM AA6605-T6
08	LIMITATORE DI CORSA	TRAVEL STOP	LIMITEUR DE COURSE	WEGBEGRENZER (NOCKEN)	ACCIAIO AL CARBONIO CARBON STEEL ACIER AU CARBONE KOHLENSTOFF-STAHL
09	O-RING SUP. PIGNONE	PINION TOP O-RING	O-RING SUPERIEUR DE PIGNON	OBERE WELLENDICHTUNG	NBR
10	BUSSOLA SUPERIORE	PINION TOP BEARING	JOINT SUPERIEUR DE PIGNON	OBERES WELLENLAGER	PTFE
11	PIGNONE	PINION	PIGNON	WELLE	ACCIAIO AL CARBONIO CARBON STEEL ACIER AU CARBONE KOHLENSTOFF-STAHL
12	O-RING INF. PIGNONE	PINION BOTTOM O-RING	O-RING INFERIEUR DE PIGNON	UNTERE WELLENDICHTUNG	NBR
13	BUSSOLA INFERIORE	PINION BOTTOM BEARING	JOINT INFERIEUR DE PIGNON	UNTERES WELLENLAGER	PTFE
17	DADO	NUT	ECROU	MUTTER	ACCIAIO INOSSIDABILE STAINLESS STEEL ACIER INOXYDABLE EDELSTAHL
18	VITE DI REGOLAZIONE	ADJUST. SCREW	VIS DE REGULATION	EINSTELLSCHRAUBE	ACCIAIO INOSSIDABILE STAINLESS STEEL ACIER INOXYDABLE EDELSTAHL
19	PISTONE	PISTON	PISTON	KOLBEN	ALLUMINIO ALUMINIUM ALUMINIUM ALUMINIUM A380.1
20	PATTINO	PISTON GUIDE	GUIDE DE PISTON	KOLBENFÜHRUNG	TECNPOLIMERO TECHNO-POLYMER TECHNO-POLYMERE TECHNO-POLYMER
21	BUSSOLA PISTONE	PISTON BEARING	JOINT DE PISTON	KOLBEN - FÜHRUNGSRING	TECNPOLIMERO TECHNO-POLYMER TECHNO-POLYMERE TECHNO-POLYMER
22	O-RING PISTONE	PISTON O-RING	O-RING DE PISTON	KOLBENDICHTUNG	NBR
23	MOLLE	SPRINGS	RESSORTS	FEDERN	ACCIAIO PER MOLLE SPRING STEEL ACIER A RESSORT FEDERSTAHL
24	O-RING FONDELLO	END CAP O-RING	O-RING D' EMBOUT	DECKELDICHTUNG	NBR
25	FONDELLO	END CAP	EMBOUT	DECKEL	ALLUMINIO ALUMINIUM ALUMINIUM ALUMINIUM A380.1
26	VITE FONDELLO	END CAP SCREW	VIS D'EMBOUT	DECKELSCHRAUBE	ACCIAIO INOSSIDABILE STAINLESS STEEL ACIER INOXYDABLE EDELSTAHL

### NOTE - NOTES - NOTES - ANMERKUNGEN:

- Disponibile nelle versioni a Semplice Effetto (S.E.) e a Doppio Effetto (D.E.).
- Available in Single Effect type (S.E.) and Double Effect type (D.E.).
- Disponible dans les versions à Simple Effet (S.E.) et à Double Effet (D.E.)
- Lieferbar in einfachwirkender (S.E.) und doppelwirkender Ausführung (D.E.)
- Pressione dell'aria di alimentazione: 3 bar min. -10bar max
- Air feeding pressure: min. 3 bar - max.10bar
- Pression d' air d'alimentation: 3 bar min. -10bar max.
- Erforderlicher Steuerdruck: min. 3 bar - max. 10 bar

- Disponibile per 3 range di temperatura: base (-20°C/+80°C), LT (-40°C/+80°C), HT (-20°C/+150°C).
- Available for 3 temperature range : base (-20°C/+80°C), LT (-40°C/+80°C), HT (-20°C/+150°C).
- Disponible pour 3 plages de température: base (-20°C/+80°C), LT (-40°C/+80°C), HT (-20°C/+150°C).
- Lieferbar in 3 Temperatureausführungen : Basis (-20°C/+80°C), LT (-40°C/+80°C), HT (-20°C/+150°C).

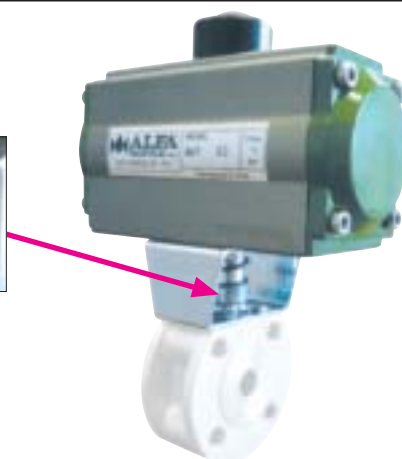



**ATTUATORI PNEUMATICI  
PNEUMATIC ACTUATORS  
ACTIONNEURS PNEUMATIQUES  
PNEUMATISCHE STELLANTRIEBE**

**PER VALVOLE "ALFA" A 3 VIE  
FOR 3 WAY "ALFA" VALVES  
POUR VANNES "ALFA" À 3 VOIES  
FÜR "ALFA" 3 WEGE KUGELHÄHN**

# AVT 120°

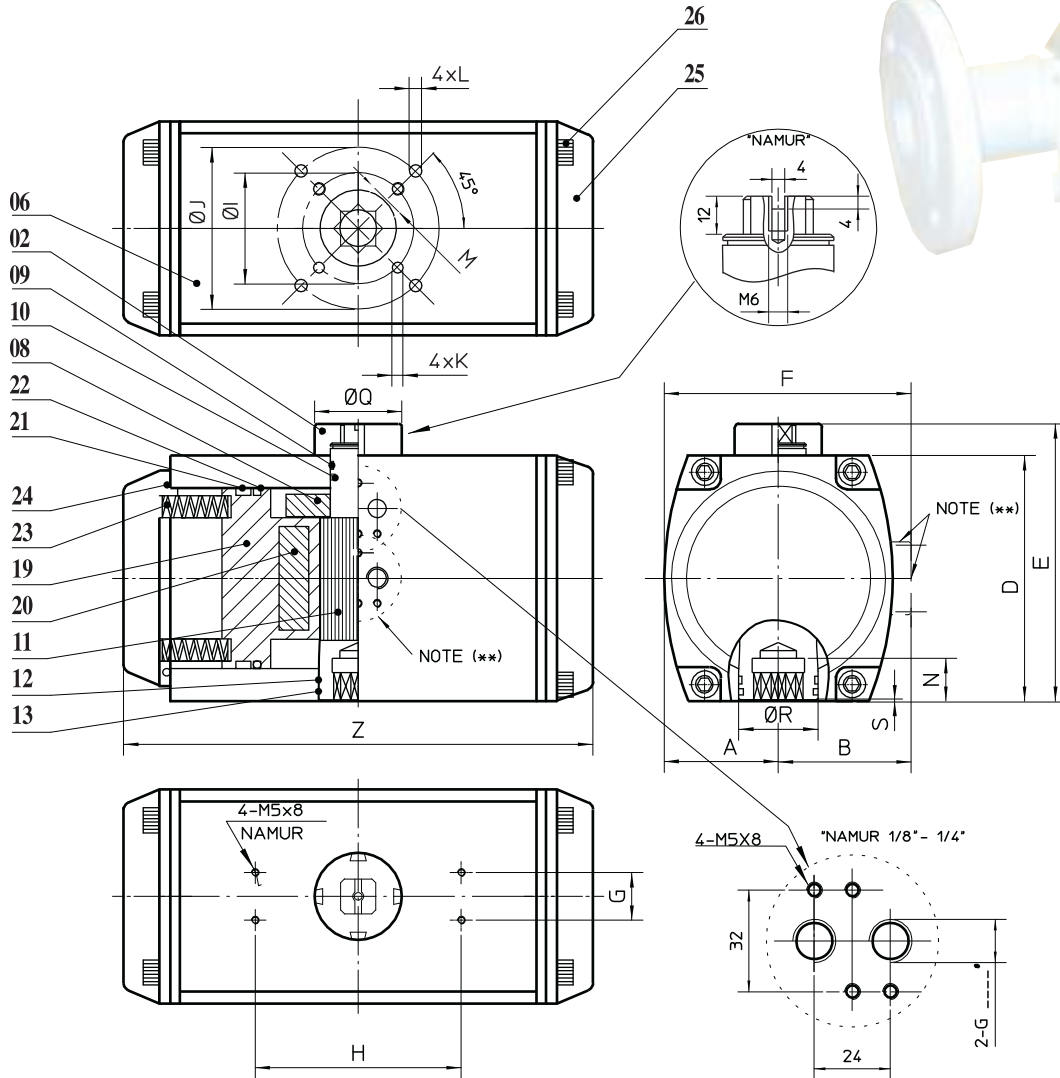
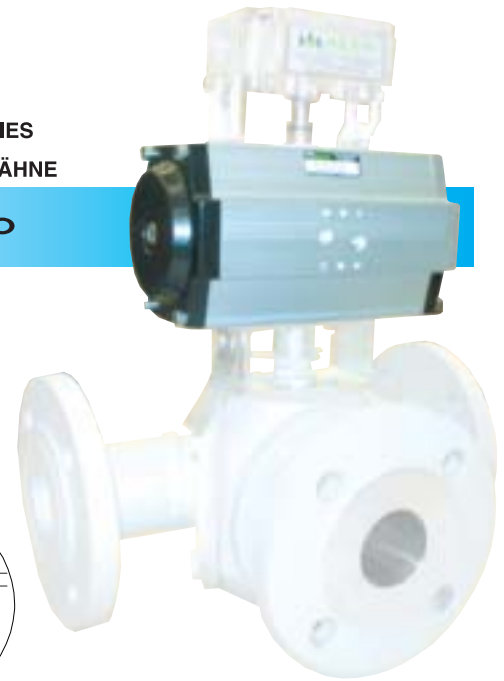

NOTA (\*\*): solo per modelli da 52 e 92, connessioni NAMUR1/8" in mezzeria (differente forma del corpo).

NOTE (\*\*): only for models 52 to 92, NAMUR connection 1/8" in middle position (different body shape).

NOTE (\*\*): seulement pour les modèles 52 à 92, connection NAMUR 1/8" au milieu (forme du corps différente).

ANMERKUNG (\*\*): nur für die Modelle 52 bis 92, NAMUR Anschlüsse 1/8" mitting angeordnet (unterschiedliche Gehäuseform).

Model	A	B	D	E	F	G	H	ØI (ISO)	ØJ (ISO)	K	L	M	N	ØQ	ØR	S	Z	Air connection	Kg
052	29	39	74	104	68	30	80	36 (F03)	50 (F05)	M5x8	M6x10	14	18	40	25	2	151	NAMUR G1/8"	1.1
063	35	44	88	118	79	30	80	50 (F05)	70 (F07)	M6x10	M8x13	14	21	40	25	2	155	NAMUR G1/8"	1.7
075	41	51	100	130	92	30	80	50 (F05)	70 (F07)	M6x10	M8x13	17	20	40	29	2	183	NAMUR G1/8"	2.5
083	45	54	108	138	99	30	80	50 (F05)	70 (F07)	M6x10	M8x13	17	20	40	32	2	205	NAMUR G1/8"	3
092	50	60	117	147	110	30	80	50 (F05)	70 (F07)	M6x10	M8x13	17	20	40	37	2	239	NAMUR G1/8"	4
110	60	60	140	170	120	30	80	70 (F07)	102 (F10)	M8x13	M10x16	22	25	40	40	2.5	251	NAMUR G1/4"	6
118	60	60	140	170	120	30	80	70 (F07)	102 (F10)	M8x13	M10x16	22	35	40	53	2.5	341	NAMUR G1/4"	8
127	68	68	160	190	137	30	80	70 (F07)	102 (F10)	M8x13	M10x16	22	36	55	53	3	348	NAMUR G1/4"	10
160	86	86	198	228	172	30	130	102 (F10)	125 (F12)	M10x16	M12x20	27	39	55	66	3	436	NAMUR G1/4"	19
210	112	112	255	285	224	30	130		140 (F14)		M16x25	36	40	55	79	4	540	NAMUR G1/4"	37
254	136	136	302	332	272	30	130		165 (F16)		M20x28	46	50	80	105	4	705	NAMUR G1/4"	66
255	136	136	302	332	272	30	130		165 (F16)		M20x28	46	50	80	134	4	809	NAMUR G1/4"	77

Proprietà riservata - A termine delle vigenti leggi, questo documento non potrà essere copiato, riprodotto o comunicato ad altre persone o a ditte senza la nostra autorizzazione scritta. All rights reserved - No part of this reproduced or transmitted, in any form or by any means, electronic, mechanical, photocopying, recording or otherwise, without the prior permission of ALFA VALVOLE s.r.l.

Le caratteristiche delle valvole, con esclusione di quelle regolamentate da Norme internazionali, possono essere oggetto di modifiche senza preavviso. Design and specifications are subject to change without notice, except those established by international standards. Ed.0004/04.09/P0001

# AVT 120°

## MATERIALI - MATERIALS - MATERIAUX - WERKSTOFFE

02	INDICATORE DI POSIZIONE	POSITION INDICATOR	INDICATEUR DE POSITION	STELLUNGSANZEIGE	PLASTICA PLASTIC PLASTIQUE KUNSTSTOFF
06	CORPO	BODY	CORPS	GEHÄUSE	ALLUMINIO ALUMINIUM ALUMINIUM ALUMINIUM ASTM 6063
08	LIMITATORE DI CORSA	TRAVEL STOP	LIMITEUR DE COURSE	WEGBEGRENZER (NOCKEN)	ACCIAIO AL CARBONIO CARBON STEEL ACIER AU CARBONE KOHLENSTOFF-STAHL
09	O-RING SUP. PIGNONE	PINION TOP O-RING	O-RING SUPERIEUR DE PIGNON	OBERE WELLENDICHTUNG	NBR
10	BUSSOLA SUPERIORE	PINION TOP BEARING	JOINT SUPERIEUR DE PIGNON	OBERES WELLENLAGER	PTFE
11	PIGNONE	PINION	PIGNON	WELLE	ACCIAIO STEEL ACIER STAHL AISI SAE 11 L37
12	O-RING INF. PIGNONE	PINION BOTTOM O-RING	O-RING INFERIEUR DE PIGNON	UTERE WELLENDICHTUNG	NBR
13	BUSSOLA INFERIORE	PINION BOTTOM BEARING	JOINT INFERIEUR DE PIGNON	UNTERES WELLENLAGER	PTFE
19	PISTONE	PISTON	PISTON	KOLBEN	ALLUMINIO ALUMINIUM ALUMINIUM ALUMINIUM UNI 5076
20	PATTINO	PISTON GUIDE	GUIDE DE PISTON	KOLBENFÜHRUNG	TECNOPOLIMERO TECHNO-POLYMER TECHNO-POLYMERE TECHNOPOLYMER
21	BUSSOLA PISTONE	PISTON BEARING	JOINT DE PISTON	KOLBEN - FÜHRUNGSRING	TECNOPOLIMERO TECHNO-POLYMER TECHNO-POLYMERE TECHNOPOLYMER
22	O-RING PISTONE	PISTON O-RING	O-RING DE PISTON	KOLBENDICHTUNG	NBR
23	MOLLE	SPRINGS	RESSORTS	FEDERN	ACCIAIO PER MOLLE SPRING STEEL ACIER A RESSORT FEDERSTAHL
24	O-RING FONDELLO	END CAP O-RING	O-RING D' EMBOUT	DECKELDICHTUNG	NBR
25	FONDELLO	END CAP	EMBOUT	DECKEL	ALLUMINIO ALUMINIUM ALUMINIUM ALUMINIUM UNI 5076
26	VITE FONDELLO	END CAP SCREW	VIS D'EMBOUT	DECKELSCHRAUBE	ACCIAIO INOSSIDABILE STAINLESS STEEL ACIER INOXYDABLE EDELSTAHL

### NOTE - NOTES - NOTES - ANMERKUNGEN:

- Disponibile nelle versioni a Semplice Effetto (S.E.) e a Doppio Effetto (D.E.)
- Available in Single Effect type (S.E.) and Double Effect type (D.E.)
- Disponible dans les versions à Simple Effet (S.E.) et à Double Effet (D.E.)
- Lieferbar in einfachwirkender (S.E.) und doppelwirkender Ausführung (D.E.)

- Pressione dell'aria di alimentazione: 3 bar min. - 10 bar max.
- Air feeding pressure: min. 3 bar - max. 10 bar
- Pression d' air d'alimentation: 3 bars min. - 10 bars max.
- Erforderlicher Steuerdruck: min. 3 bar - max. 10 bar

- Disponibile per 3 range di temperatura: base (-20°C/+80°C), LT (-40°C/+80°C), HT (-20°C/+150°C).
- Available for 3 temperature range : base (-20°C/+80°C), LT (-40°C/+80°C), HT (-20°C/+150°C).
- Disponible pour 3 plages de température: base (-20°C/+80°C), LT (-40°C/+80°C), HT (-20°C/+150°C).
- Lieferbar in 3 Temperatureausführungen : Basis (-20°C/+80°C), LT (-40°C/+80°C), HT (-20°C/+150°C).



**RIDUTTORI MANUALI  
MANUAL GEARBOXES  
REDUCTEURS MANUELS  
HANDGETRIEBE**

PER VALVOLE "ALFA" A VIA DIRITTA  
FOR STRAIGHT WAY "ALFA" VALVES  
POUR VANNES "ALFA" À VOIE UNIQUE  
FÜR "ALFA" DURCHGANGSKUGELHÄHNE

# AVM

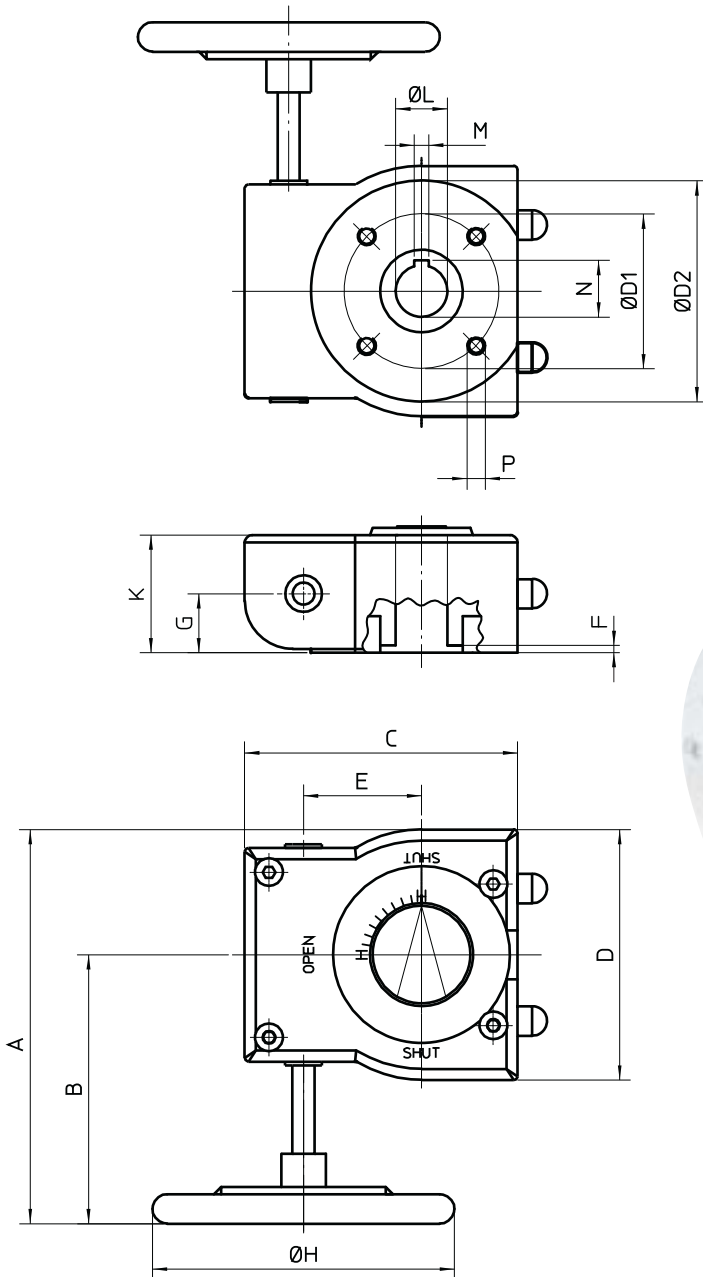

Model	A	B	C	D	E	F	G	ØH	K	ØL	M	N	ØD1	P	ØD2	Output torque (Nm)	Weight (Kg)	Body Material
AVM-010	150	110	98	80	42.5	1.5	26	100	48	25	6	27.5	50	M6	80	150	1.9	Aluminium
													70	M8				
AVM-015	169	119	115	100	50	4	27	120	55	32	6	35	70	M8	89	250	3	Aluminium
AVM-050	296	223	155	146	60	5.5	38	300	71	45	10	48.5	102	M10	140	750	5.2	Aluminium
AVM-120	410	323	212	175	80	5	39.5	400	80	54	16	57.8	140	M16	175	1200	9.2	Aluminium
AVM-250	317	217	255	210	95	5	48	360	105	38	10	41.4	140	M16	200	2500	45	Cast Iron

Proprietà riservata - A termine delle vigenti leggi questo documento non potrà essere copiato, riprodotto o comunicato ad altre persone o a ditte senza la nostra autorizzazione scritta.  
All rights reserved - No part of this reproduced or transmitted, in any form or by any means, electronic, mechanical, photocopying, recording or otherwise, without the prior permission of ALFA VALVOLE s.r.l.

Ed.0004/04\_09/P0001

Le caratteristiche delle valvole, con esclusione di quelle regolamentate da Norme internazionali, possono essere oggetto di modifiche senza preavviso  
Design and specifications are subject to change without notice, except those established by international standards.

**RIDUTTORI MAN. DISINSERIBILI  
DECLUTCHABLE GEARBOXES  
REDUCTEURS MAN. DEBRAYABLES  
AUSKUPPELBARES HANDGETRIEBE**

**PER VALVOLE "ALFA" A VIA DIRITTA  
FOR STRAIGHT WAY "ALFA" VALVES  
POUR VANNES "ALFA" A VOIE UNIQUE  
FÜR "ALFA" DURCHGANGSKUGELHÄHNE**

# AVD

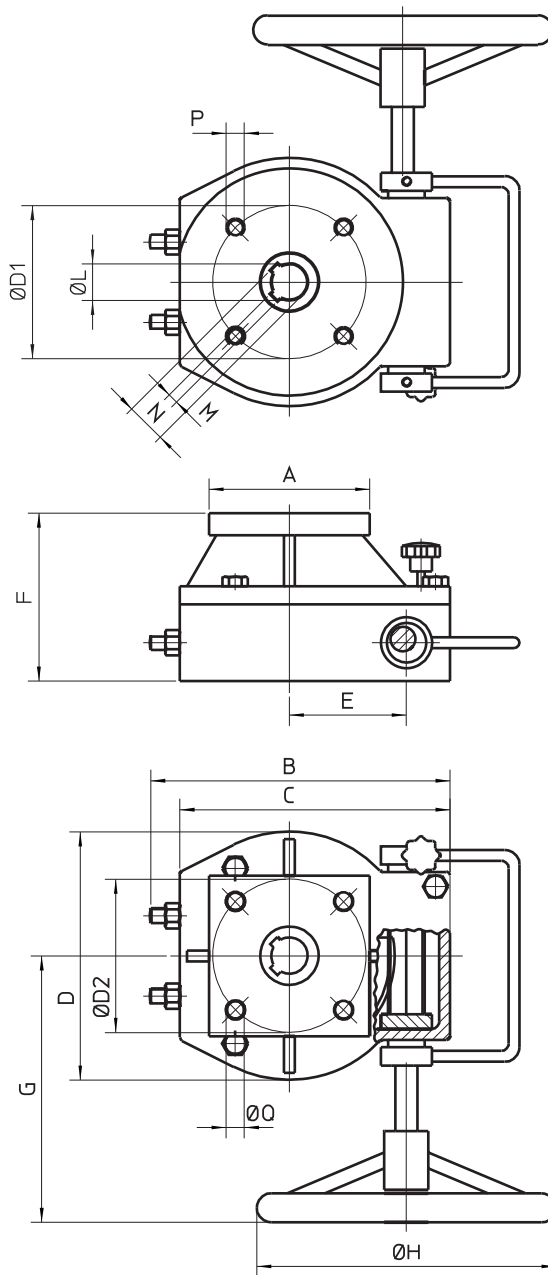

Model	A	B	C	D	E	F	G	ØH	ØL	M	N	ØD1	P	ØD2	ØQ	Weight (Kg)	Body Material
AVD-026	70	160	145	110	50.5	99	155	200	22	6	25.4	70	M8	70	9	7.3	Ductile Iron
AVD-038	110	195	175	140	65	117	195	200	38	10	41.3	102	M10	102	12	11.8	Ductile Iron
AVD-054	130	235	215	180	85	118	205	300	48	14	51.8	140	M16	140	18	17.3	Ductile Iron
AVD-080	156	320	298	250	124	148	245	400	60	18	64.4	165	M20	165	22	35	Ductile Iron
AVD-078	220	360	340	285	142	150	265	600	80	18	84.4	165	M20	165	22	48.2	Ductile Iron
AVD-098	230	550	530	460	229	195	410	800	80	18	84.4	165	M20	165	22	156	Ductile Iron
AVD-100	300	605	585	520	258	195	430	800	100	20	105.3	254	M16	254	18	190	Ductile Iron

Proprietà riservata - A termine delle vigenti leggi questo documento non potrà essere copiato, riprodotto o comunicato ad altre persone o a ditte senza la nostra autorizzazione scritta.  
All rights reserved - No part of this reproduced or transmitted, in any form or by any means, electronic, mechanical, photocopying, recording or otherwise, without the prior permission of ALFA VALVOLE s.r.l.

Ed.0004/04.09/P0001





Le caratteristiche delle valvole, con esclusione di quelle regolamentate da Norme internazionali, possono essere oggetto di modifiche senza preavviso  
Design and specifications are subject to change without notice, except those established by international standards.



20010 CASOREZZO (Milano) - ITALIA -  
VIALE DEL LAVORO, 19  
Tel. 02.90296206 r.a. - Telefax 02.90296292  
E-Mail: [alfavalvole@alfavalvole.it](mailto:alfavalvole@alfavalvole.it) - Sito internet: [www.alfavalvole.it](http://www.alfavalvole.it)

**BOX FINECORSA**  
**LIMIT SWITCH BOX**  
**BOITIER FIN DE COURSES**  
**ENDSCHALTERBOX**

**BOX FINECORSA**

	<b>AVB</b>	<b>SM</b>	<b>SB / SIB</b>	<b>SX</b>
				
<b>DIMENSIONI</b> DIMENSIONS DIMENSIONS ABMESSUNGEN			<b>A SICUREZZA INTRINSECA</b> INTRINSICALLY SAFE <b>À SECURITE INTRINSEQUE</b> EIGENSICHER	<b>ANTIDEFAGRANTE</b> EXPLOSION PROOF <b>ANTI-DEFAGRANT</b> EXPLOSIONS GESCHÜTZTES
<b>A</b>	112	90	120	170
<b>B</b>	88	82	80	140
<b>C</b>	77	66	90	137
<b>S</b>	25	4	25	25
<b>INGRESSO CAVI</b> CABLE ENTRY <b>ENTREE DES CABLES</b> KABELVERSCHRAUBUNG	M20x1.5	M20x1.5	M20x1.5	1/2"NPT

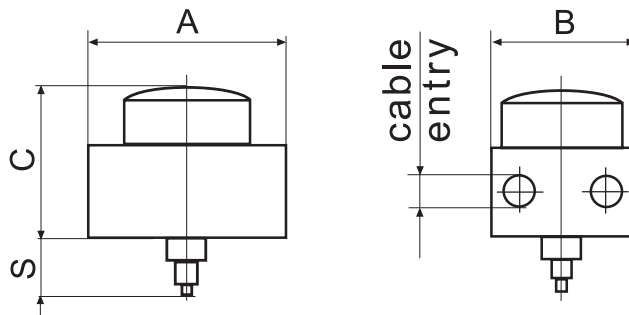

<b>MATERIALI</b> MATERIALS <b>MATERIAUX</b> WERKSTOFFE				
<b>CORPO</b> BODY <b>CORPS</b> GEHÄUSE	ALLUMINIO VERNICIATO COATED ALUMINIUM ALUMINIUM VERNIS BESCHICHTETES ALUMINIUM	ALLUMINIO NICHELATO ALUMINIUM NICKEL PLATED ALUMINIUM NICKELE ALUMINIUM VERNICKELT	ALLUMINIO VERNICIATO COATED ALUMINIUM ALUMINIUM VERNIS BESCHICHTETES ALUMINIUM	ALLUMINIO VERNICIATO COATED ALUMINIUM ALUMINIUM VERNIS BESCHICHTETES ALUMINIUM
<b>COPERCHIO</b> COVER <b>COUVERCLE</b> DECKEL	ALLUMINIO VERNICIATO COATED ALUMINIUM ALUMINIUM VERNIS BESCHICHTETES ALUMINIUM	POLICARBONATO POLYCARBONATE POLYCARBONATE POLYKARBONAT	POLICARBONATO POLYCARBONATE POLYCARBONATE POLYKARBONAT	ALLUMINIO VERNICIATO COATED ALUMINIUM ALUMINIUM VERNIS BESCHICHTETES ALUMINIUM
<b>STELO</b> SHAFT <b>AXE</b> WELLE	ACCIAIO INOSSIDABILE STAINLESS STEEL ACIER INOXYDABLE EDELSTAHL	TECNOPOLIMERO TECHNO POLYMER TECHNO-POLYMER TECHNOPOLYMER	ACCIAIO INOSSIDABILE STAINLESS STEEL ACIER INOXYDABLE EDELSTAHL	ACCIAIO INOSSIDABILE STAINLESS STEEL ACIER INOXYDABLE EDELSTAHL
<b>VITI</b> FASTENERS <b>VIS</b> SCHRAUBEN	ACCIAIO INOSSIDABILE STAINLESS STEEL ACIER INOXYDABLE EDELSTAHL	ACCIAIO INOSSIDABILE STAINLESS STEEL ACIER INOXYDABLE EDELSTAHL	ACCIAIO INOSSIDABILE STAINLESS STEEL ACIER INOXYDABLE EDELSTAHL	ACCIAIO INOSSIDABILE STAINLESS STEEL ACIER INOXYDABLE EDELSTAHL
<b>INDICATORE</b> INDICATOR <b>INDICATEUR</b> ANZEIGE	VISIVO 3D VISUAL 3D VISION 3D 3D ANZEIGE	VISIVO 3D VISUAL 3D VISION 3D 3D ANZEIGE	VISIVO 3D VISUAL 3D VISION 3D 3D ANZEIGE	VISIVO 3D VISUAL 3D VISION 3D 3D ANZEIGE
<b>GRADO DI PROTEZIONE</b> WEATHER PROOF PROTECTION <b>CLASSE DE PROTECTION</b> SCHUTZART	IP67	IP65	IP67	IP67
<b>FINECORSA IN OPZIONE</b> LIMIT SWITCH OPTIONS <b>FIN DE COURSE EN OPTION</b> SCHALTERAUSFÜHRUNGEN	SPDT ELETTROMECCANICO SPDT ELECTROMECHANICAL SPDT ELECTRO-MECANIQUE SPDT MECHANISCHER WECHSELSCHALTER	SPDT ELETTROMECCANICO SPDT ELECTROMECHANICAL SPDT ELECTRO-MECANIQUE SPDT MECHANISCHER WECHSELSCHALTER  INDUTTIVI: NAMUR-PNP-NO PROXIMITY SWITCH: NAMUR-PNP-NO DETECTEURS DE PROXIMITE: NAMUR-PNP-NO NÄHRUNGSSCHALTER: NAMUR-PNP-NO	SPDT ELETTROMECCANICO SPDT ELECTROMECHANICAL SPDT ELECTRO-MECANIQUE SPDT MECHANISCHER WECHSELSCHALTER  INDUTTIVI: NAMUR-PNP-NO PROXIMITY SWITCH: NAMUR-PNP-NO DETECTEURS DE PROXIMITE: NAMUR-PNP-NO NÄHRUNGSSCHALTER: NAMUR-PNP-NO	SPDT ELETTROMECCANICO SPDT ELECTROMECHANICAL SPDT ELECTRO-MECANIQUE SPDT MECHANISCHER WECHSELSCHALTER  INDUTTIVI: NAMUR-PNP-NO PROXIMITY SWITCH: NAMUR-PNP-NO DETECTEURS DE PROXIMITE: NAMUR-PNP-NO NÄHRUNGSSCHALTER: NAMUR-PNP-NO
<b>ATEX</b>		Ex II2 GD EEx ia IIC T6	Ex II2 GD EEx ia IIC T6	Ex II2 GD EEx d IIB T6

Proprietà riservata - A termine delle vigenti leggi questo documento non potrà essere copiato, riprodotto o comunicato ad altre persone o a ditte senza la nostra autorizzazione scritta. All rights reserved - No part of this reproduced or transmitted, in any form or by any means, electronic, mechanical, photocopying, recording or otherwise, without the prior permission of ALFA VALVOLE s.r.l.

Ed.0004/04.09/P0001

Le caratteristiche delle valvole, con esclusione di quelle regolate da norme internazionali, possono essere oggetto di modifiche senza preavviso. Design and specifications are subject to change without notice, except those established by international standards.



2010 CASOREZZO (Milano) - ITALIA -  
 VIALE DEL LAVORO, 19  
 Tel. 02.90296206 r.a. - Telefax 02.90296292  
 E-Mail: alfavalvole@alfavalvole.it - Sito internet: www.alfavalvole.it



**ELETTROVALVOLE  
SOLENOID VALVES  
ELECTRODISTRIBUTEURS  
MAGNETVENTILE**

**ELETTROVALVOLE**

TIPO TYPE TYPE TYP	CARATTERISTICHE FEATURES CARACTERISTIQUES MERKMALE	GRADO DI PROTEZIONE WEATHER PROOF PROTECTION CLASSE DE PROTECTION SCHUTZART	ATEX	ATTACCHI CONNECTIONS CONNEXIONS ANSCHLÜSSE	
				ARIA AIR AIR LUFT	ELETRICA ELECTRIC ELECTRIQUE ELEKTRISCHE
 <p>MONOSTABILE 3/2-5/2 SINGLE SOLENOID SIMPLE SOLENOIDE 3/2 - 5/2 WEGE</p>	<p>CONNESSIONE NAMUR+ COMANDO MANUALE NAMUR CONNECTION + MANUAL OPERATOR EMBASE NAMUR + COMMANDE MANUELLE ANSCHLÜSSE NACH NAMUR UND NOTHANDBETÄTIGUNG</p>	IP 65	---	1/4" GAS	<p>PG9 CONNETTORE PG9 CONNECTOR PG9 CONNECTEUR KABELVERSCHRAUBUNG PG9</p>
 <p>BISTABILE DOUBLE SOLENOID DOUBLE SOLENOIDE IMPULS AUSFÜHRUNG</p>	<p>CONNESSIONE NAMUR + COMANDO MANUALE NAMUR CONNECTION + MANUAL OPERATOR EMBASE NAMUR + COMMANDE MANUELLE ANSCHLÜSSE NACH NAMUR UND NOTHANDBETÄTIGUNG</p>	IP 65	---	1/4" GAS	<p>PG9 CONNETTORE PG9 CONNECTOR PG9 CONNECTEUR KABELVERSCHRAUBUNG PG9</p>
 <p>ANTIDEFLAGRANTE EXPLOSION PROOF ANTI-DÉFLAGRANT EXPLOSIONS GESCHÜTZTES</p>	<p>CONNESSIONE NAMUR + COMANDO MANUALE NAMUR CONNECTION + MANUAL OPERATOR EMBASE NAMUR + COMMANDE MANUELLE ANSCHLÜSSE NACH NAMUR UND NOTHANDBETÄTIGUNG</p>	IP 67	EEx d IIB + H2	1/4" GAS	3/4" GAS
 <p>A SICUREZZA INTRINSECA INTRINSICALLY SAFE À SECURITE INTRINSEQUE EIGENSICHER</p>	<p>CONNESSIONE NAMUR + COMANDO MANUALE NAMUR CONNECTION + MANUAL OPERATOR EMBASE NAMUR + COMMANDE MANUELLE ANSCHLÜSSE NACH NAMUR UND NOTHANDBETÄTIGUNG</p>	IP 65	EEx ia IIC T6	1/4" GAS	<p>PG11 CONNETTORE PG11 CONNECTOR PG11 CONNECTEUR KABELVERSCHRAUBUNG PG11</p>
 <p>A SICUREZZA AUMENTATA INCREASED SAFETY À SECURITE AUGMENTE ERHÖHTER SICHERHEIT</p>	<p>CONNESSIONE NAMUR + COMANDO MANUALE NAMUR CONNECTION + MANUAL OPERATOR EMBASE NAMUR + COMMANDE MANUELLE ANSCHLÜSSE NACH NAMUR UND NOTHANDBETÄTIGUNG</p>	IP 65	EEx me IIC T5	1/4" GAS	M20 x 1.5
 <p>UNIVERSALE UNIVERSAL UNIVERSEL UNIVERSAL</p>	<p>CONNESSIONE 1/4" GAS CONNECTION 1/4" GAS CONNEXION 1/4" GAS ANSCHLÜSSE 1/4" GAS</p>	IP 65	<p>ANTIDEFLAGRANTE EXPLOSION PROOF ANTI-DEFLAGRANT EXPLOSIONSGESCHÜTZTES A SICUREZZA INTRINSECA INTRINSICALLY SAFE À SECURITE INTRINSEQUE EIGENSICHER A SICUREZZA AUMENTATA INCREASED SAFETY À SECURITE AUGMENTE ERHÖHTER SICHERHEIT</p>	1/4" GAS	---

Proprietà riservata - A termine delle vigenti leggi, questo documento non potrà essere copiato, riprodotto o comunicato ad altre persone o a ditte senza la nostra autorizzazione scritta. All rights reserved - No part of this reproduced or transmitted, in any form or by any means, electronic, mechanical, photocopying, recording or otherwise, without the prior permission of ALFA VALVOLE s.r.l.

Le caratteristiche delle valvole, con esclusione di quelle regolamentate da Norme internazionali, possono essere oggetto di modifiche senza preavviso. Design and specifications are subject to change without notice, except those established by international standards.





2010 CASOREZZO (Milano) - ITALIA -  
VIALE DEL LAVORO, 19  
Tel. 02.90296206 r.a. - Telefax 02.90296292  
E-Mail: alfavalvole@alfavalvole.it - Sito internet: www.alfavalvole.it

# ACCESSORI



## POSIZIONATORI POSITIONERS POSITIONNEURS STELLUNGSREGLER

	TIPOLOGIE TYPES TYPES TYPEN	ATEX	OPZIONI OPTIONS OPTIONS OPTIONEN	MATERIALE CORPO BODY MATERIAL MATÉRIEL DU CORPS GEHÄUSE WERKSTOFF
	<b>PNEUMATICO 3-15 psi ELETTROPNEUMATICO 4-20mA</b> PNEUMATIC 3-15 psi ELECTROPNEUMATIC 4-20mA <b>PNEUMATIQUE 3-15 psi ELECTRO-PNEUMATIQUE 4-20 mA</b> PNEUMATISCH 3-15 psi ELEKTROPNEUMATISCH 4-20 mA	<b>ANTIDEFLAGRANTE EXPLOSION PROOF ANTI-DEFLAGRANT EXPLOSIONS GESCHÜTZTES</b> Ex II G EEx d IIC T6  <b>A SICUREZZA INTRINSECA INTRINSICALLY SAFE SECURITE INTRINSEQUE EIGENSICHER</b> Ex II G EEx ia IIC T6	<b>SPDT ELETTROMECCANICO SPDT ELECTROMECHANICAL SPDT ELECTRO-MECANIQUE SPDT MECHANISCHER WECHSELSCHALTER</b>	<b>ALLUMINIO VERNICIATO TECNOPOLIMERO PAINTED ALLUMINIUM TECHNOPOLYMER ALUMINIUM VERNIS TECHNO-POLYMERE BESCHICHTETES ALLUMINIUM TECHNOPOLYMER</b>

## FILTRI REGOLATORI E MANOMETRI FILTER REGULATORS AND PRESSURE GAUGES FILTRES REGULATEURS ET MANOMETRES FILTERREGLER UND MANOMETER

			MATERIALI MATERIALS MATERIAUX WERKSTOFFE	ATTACCHI CONNECTIONS CONNEXIONS ANSCHLÜSSE
			<b>ALLUMINIO/ACCIAIO INOSSIDABILE</b> ALLUMINIUM/ STAINLESS STEEL <b>ALUMINIUM/ACIER INOXYDABLE</b> ALUMINIUM/EDELSTAHL	1/8" 1/4" 1/2" GAS O NPT

## REGOLATORI DI SCARICO SILENZIATI E SCARICHI RAPIDI EXHAUST REGULATORS FILTRES D'ÉCHAPPEMENTS DROSSELSCHALLDÄMPFER UND SCHALLDÄMPFER

			MATERIALE MATERIAL MATERIEL WERKSTOFF	ATTACCHI CONNECTIONS CONNEXIONS ANSCHLÜSSE
			<b>ALLUMINIO ACCIAIO INOSSIDABILE</b> ALLUMINIUM STAINLESS STEEL <b>ALUMINIUM ACIER INOXYDABLE</b> ALUMINIUM EDELSTAHL	1/8" 1/4" 1/2" GAS O NPT

## REGOLATORI DI PORTATA FLOW REGULATORS REGULATEURS DE DEBITS DURCHFLOßREGLER

		MATERIALE MATERIAL MATERIEL WERKSTOFF	ATTACCHI CONNECTIONS CONNEXIONS ANSCHLÜSSE
		<b>ALLUMINIO ACCIAIO INOSSIDABILE</b> ALLUMINIUM STAINLESS STEEL <b>ALUMINIUM ACIER INOXYDABLE</b> ALUMINIUM EDELSTAHL	1/8" 1/4" 1/2" GAS O NPT



**ATTUATORI PNEUMATICI A GLIFO SCOTCH-YOKE PNEUMATIC ACTUATORS**  
**ACTIONNEURS PNEUMATIQUES A COUPLES ELEVES SCOTCH YOKE PNEUMATIKANTRIEB**



**ATTUATORI GAS OVER OIL GAS OVER OIL ACTUATORS ACTIONNEURS GAS OVER OIL GAS HYDRAULISCHE STELLANTRIEBE**



**ATTUATORI ELETTRICI ELECTRIC ACTUATORS ACTIONNEURS ELECTRIQUES ELEKTRISCHE ANTRIEBE**

Proprietà riservata - A termine delle vigenti leggi questo documento non potrà essere copiato, riprodotto o comunicato ad altre persone o a ditte senza la nostra autorizzazione scritta.  
 All rights reserved - No part of this reproduced or transmitted, in any form or by any means, electronic, mechanical, photocopying, recording or otherwise, without the prior permission of ALFA VALVOLE s.r.l.

Ecd.0004/04.09/P0001

Le caratteristiche delle valvole, con esclusione di quelle regolamentate da Norme internazionali, possono essere oggetto di modifiche senza preavviso  
 Design and specifications are subject to change without notice, except those established by international standards.



2010 CASOREZZO (Milano) - ITALIA -  
 VIALE DEL LAVORO, 19  
 Tel. 02.90296206 r.a. - Telefax 02.90296292 -  
 E-Mail: [alfavalvole@alfavalvole.it](mailto:alfavalvole@alfavalvole.it) - Sito internet: [www.alfavalvole.it](http://www.alfavalvole.it)



Proprietà riservata - A termine delle vigenti leggi questo documento non potrà essere copiato, riprodotto o comunicato ad altre persone o a ditte senza la nostra autorizzazione scritta.  
All rights reserved - No part of this reproduced or transmitted, in any form or by any means, electronic, mechanical, photocopying, recording or otherwise, without the prior permission of ALFA VALVOLE s.r.l.



Le caratteristiche delle valvole, con esclusione di quelle regolamentate da Norme internazionali, possono essere oggetto di modifiche senza preavviso  
Design and specifications are subject to change without notice, except those established by international standards.

Ed.0004/04.09/P0001



20010 CASOREZZO (Milano) - ITALIA -  
VIALE DEL LAVORO, 19  
Tel. 02.90296206 r.a. - Telefax 02.90296292 -  
E-Mail: [alfavalvole@alfavalvole.it](mailto:alfavalvole@alfavalvole.it) - Sito internet: [www.alfavalvole.it](http://www.alfavalvole.it)